

# Transmitters

## Instructions for Models: ML-143(1,2,4), ML-243(1,2,4), ML-343(1) ML-140(1,2,4), ML-240(1,2,4), ML-139(1,2,4), ML-239(1,2,4)

### FEATURES

A family of state-of-the-art transmitters is tailored for discerning homeowner's. Each transmitter is custom encoded and ergonomically designed to be an integral part of your garage door opener system. Offering 3 styles to suit your personal preference: the Midi (1-, 2- or 4-channel), the Mini (1-, 2- or 4-channel), and the Micro (1-channel), the smallest transmitter of its kind.

### 1. Installing the Battery

#### Midi (Figure 1.A) and Mini (Figure 1.B)

- Remove battery compartment cover (back of transmitter) by using small screwdriver.
- Insert the provided 12V battery (type 23A) as shown.
- Replace battery compartment cover.

#### Micro (Figure 1.C)

Micro transmitters come with batteries already installed. When replacing batteries follow the steps below:

- Remove battery compartment cover (front of transmitter).
- Insert two 3V batteries (type CR1025) as shown.
- Replace battery compartment cover.

*Note: Replace batteries with same type only.*

### 2. Using the Transmitter

- To open or close garage door, press and hold button (Midi and Mini transmitters have indicator lights that will start blinking). When garage door begins to move, release button.
- To stop garage door during travel, press and hold button until door stops, then release button.
- To continue garage door travel after stopping it, press and hold button. Once pressed, the door will travel in the opposite direction.

### 3. Transmitter Mounting

The transmitters can be conveniently mounted inside your car using the mounting plate, or the mounting plate and visor clip (Midi and Mini Transmitters only).

#### Mounting Plate (Figure 2.)

The mounting plate enables you to mount the transmitter easily to the dashboard or other convenient area.

- Secure the mounting plate to area of preference using velcro (not provided) or other means.
- Snap the transmitter into the mounting plate, which will hold it firmly in place.

#### Visor Clip (Midi and Mini Transmitters: Figure 2.)

The visor clip permits easy mounting of the transmitter to a visor.

- Attach visor clip to mounting plate.
- Snap transmitter into mounting plate.
- Affix complete assembly to visor.

Figure 1. Battery Compartment

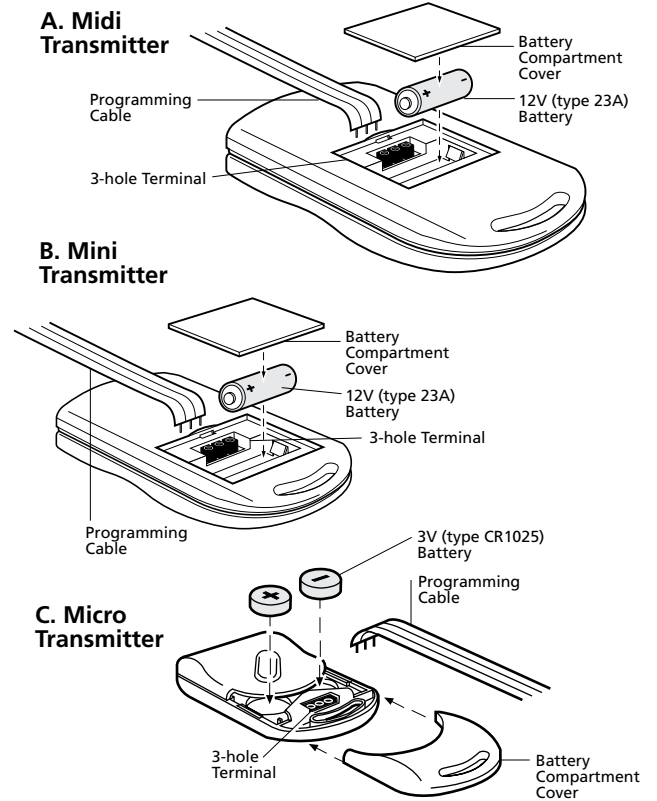
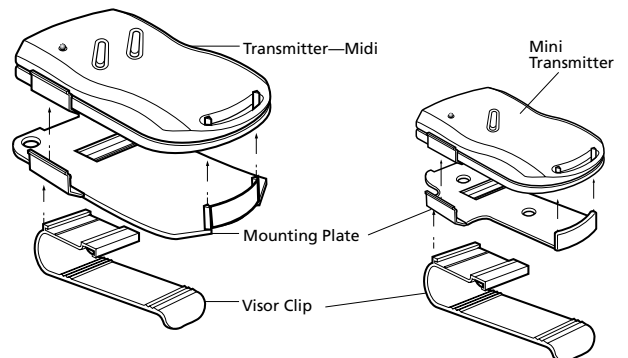
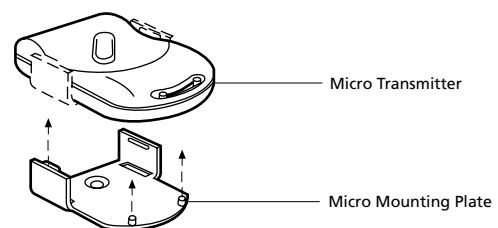

Figure 2. Mounting Plates & Visor Clips

#### A. Midi or Mini Transmitter



#### B. Micro Transmitter



# Transmitters

## Instructions (continued)

### 4. Multiple Transmitters

Each transmitter comes factory programmed with random codes. 1-channel transmitters have one random code, 2-channel transmitters have 2 different random codes, one per button, and 4-channel transmitters have 4 different random codes, one per button. Transmitters that accompany a power head have at least one code that already matches that power head. Transmitters that are purchased separately as accessories have random codes that must be changed in order to match the code of the "active" transmitter you are already using. Below are instructions for transferring an active code from a button on one transmitter to a button of your choice on another transmitter.

- Remove battery compartment covers (as shown previously in Figure 1) of both transmitters, the one with the active code and the new transmitter that needs to receive the active code.
- Connect programming cable to both transmitters. Line up either end of the stripped cable so 3 wires align with 3-hole terminal, then firmly insert cable. See Figure 3.
- Press and hold button on transmitter with the active code ((L) in Figure 3). Midi and Mini transmitters have indicator lights that will blink to show that code transfer is ready.
- While keeping the transmitter (L) button pressed, press and hold the button on the new transmitter (R) that you want to transfer the active code to.
- Code transfer will occur in approximately 2 seconds. If the new transmitter (R) is a Midi or a Mini, the indicator light will illuminate continuously to show that transfer is complete.
- All buttons can be released. Code transfer is completed.
- Cable can be removed and the covers replaced.
- Both transmitters can now be used to operate the same door.

*Note: For multi-button transmitters, be sure to carry out this procedure for all the buttons you desire to use.*

*For micro transmitters, follow the same steps only there will be no LED light indication.*

### 5. Changing the Code on Transmitters

The transmitter factory preset code can be changed as follows:

#### LIMITED WARRANTY:

Transmitters (model #'s ML-143(1,2,4), ML-243(1,2,4), ML-343(1), ML-140(1,2,4), ML-240(1,2,4), ML-139(1,2,4), ML-239(1,2,4) - (1) Year Warranty (Labor not included)

**COVERAGE:** Any defect in material and or workmanship from personal, normal household use in accordance with the Owner's Manual.

**WARRANTY OWNERSHIP:** The warranty is limited to the consumer who originally purchased and/or registered the product.

**MARANTEC AMERICA CORPORATION COMMITMENT:** If the Marantec® product is found to be defective, we will repair or, at our option, replace it at no charge to the customer. We may elect to use new or reconditioned replacement parts or product of the same or similar design at that given time.

**LIMITATIONS:** Marantec® will not be liable for loss or damage to property or any incidental or consequential loss or expense from property damage due directly or indirectly from the use of this product other than in the States that do not allow such exclusion of limitation. Marantec® will not cover batteries, unauthorized repair parts, installa-

**Figure 3. Multiple Transmitters—Code Transfer**

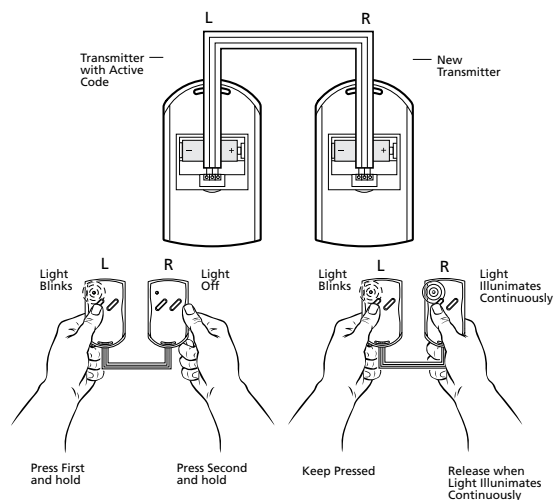

- Remove battery cover from compartment.
- Connect the programming 3-prong cable to programming terminal in transmitter. Fig. 3A.
- Cross any two wires of the programming cable, one of them must be the center wire.
- Press and hold the button on the transmitter.
- Code will change in approximately 2 seconds.
- Release the button after the light illuminates continuously then remove the cable and replace the cover.

**Figure 3A. Code Changing**

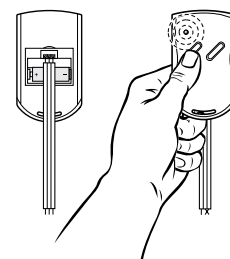

*Note: For multi-button transmitters, be sure to carry out this procedure for all the buttons you desire to use.*

*For micro transmitters, follow the same steps only there will be no LED light indication.*

tions, commercial use, damage while in transit, defects resulting from accidents, or resulting from alterations, lack of proper maintenance, unauthorized repair or modification of product, misuse or abuse of product, fire, flood, or acts of God, or other failures due to not properly following the *Marantec® Owner's Manual*. No labor costs are covered. This warranty applies only to Marantec's Accessories purchased and used in the United States, Canada, or Mexico. Marantec® under no circumstances will be liable for consequential, incidental or special damages arising in connection with the use, or inability to use, this product. In no event shall Marantec's liability for breach of warranty, breach of contract, negligence or strict liability exceed the cost of the product covered hereby. No person is authorized to assume for Marantec America Corporation any other liability in connection with the sale of this product.

**WARRANTY SERVICE:** Service from Authorized Dealers: Contact the source that sold you and/or installed your Garage Door Opener unit.

Self-Service: Call Marantec's Toll Free Helpline at: 1-888-622-2489 where a trained Marantec® representative will assist you in diagnosing and providing you with directions and parts to repair it yourself if possible.

FCC Certified: This device complies with Part 15 of the FCC rules. Operation is subject to the following two conditions: (1) this device may not cause harmful interference, and (2) this device must accept any interference received, including interference that may cause undesired operation.

Changes or modifications not expressly approved by the party responsible for compliance could void the user's authority to operate the equipment.